



vSystem

C.A.R.B. E.O. No. D-674

Register your limited warranty online @ www.scottoiler.com/guarantee



Technical Support



support@scottoiler.com



1-866-995-9340



YouTube



flickr

Visit our pages on Facebook, YouTube, Twitter or flickr

1a. Vacuum Connection - California spec models

! To comply with CARB regulations, CARB Sticker (part 20) must be stuck onto either the bike near the RMV (reservoir), or onto the reservoir itself.

Models of motorcycles sold in California are equipped with evaporative emissions canisters which collect gas vapor from the gas tank.

On these models there will be a **vacuum hose from the engine to this canister**, and also a hose from the gas tank to this canister.

Model specific details can be found at www.scottoiler.com

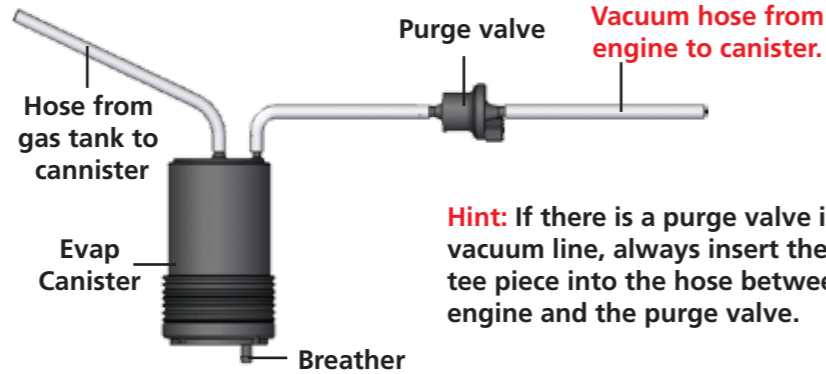

Hint: If there is a purge valve in the vacuum line, always insert the Scottoil tee piece into the hose between the engine and the purge valve.

Locate the **vacuum hose from the engine to the canister**. Cut into vacuum hose and insert T-piece. Fit the Scottoil vacuum tubing (part 3) into the small side of the damper elbow (part 4) & press the larger side of the damper elbow onto T-piece.

Hint: Ensure all connections are firmly made, and lubricate the damper elbow with a little Scottoil for easier installation.

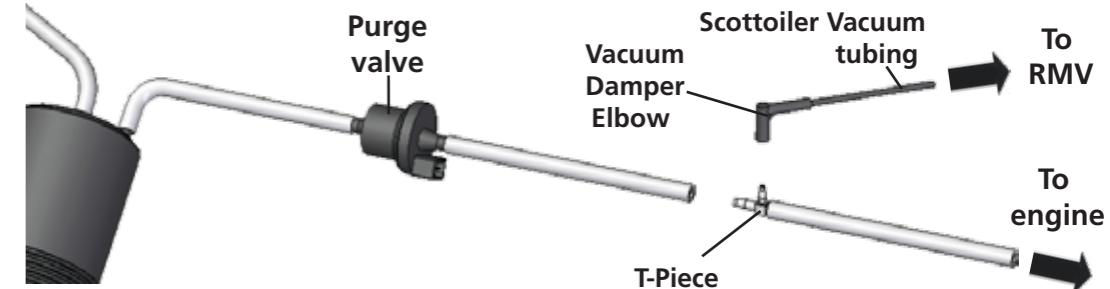

1b. Vacuum Connection - Other states

Hint: Model specific details and photos of vacuum connections can be found online at www.scottoiler.com

Locate the vacuum tubing and cut. Insert T-piece (part 7). Fit the Scottoil vacuum tubing (part 3) into the small end of the vacuum damper elbow part (part 4) then press the larger end of the damper elbow onto T-piece.

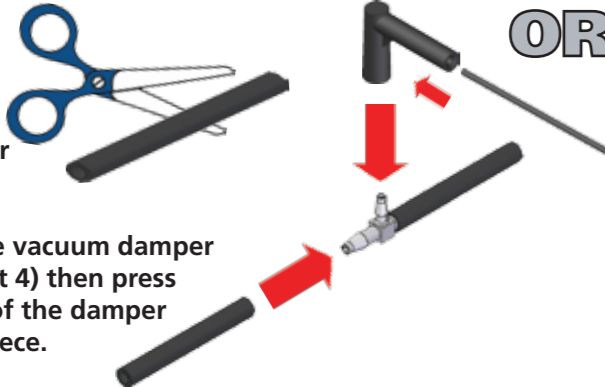

OR Locate vacuum screw. Remove screw and replace with M5 or M6 spigot (part 5 or part 6) as appropriate. Fit the Scottoil vacuum tubing (part 3) into the small end of the vacuum damper elbow part (part 4).

Lubricate the spigot with a drop of Scottoil to assist assembly then press the large end of the vacuum damper elbow part onto spigot.



OR Locate vacuum spigot with rubber bung. Remove rubber bung. Fit the Scottoil vacuum tubing (part 3) into the small end of the vacuum damper elbow part (part 4). Lubricate spigot with a drop of Scottoil to assist assembly then press the large end of the vacuum damper elbow part onto the spigot.



2. Dispenser Assembly - 4 most common options

! Incorrect installation can result in excessive oil fling

For ALL installations the optimum feed point is between the 5 & 7 o'clock on the face of the rear sprocket.

Nib can be trimmed if necessary and should lightly touches sprocket with slash cut facing out.

Spin wheel forward and back to ensure nib cannot be trapped.

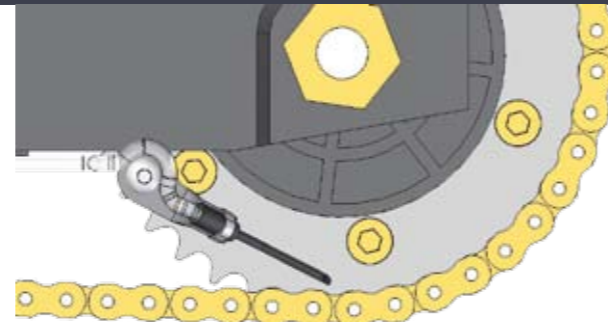

Bobbin Mount (parts 15 & 16)

OR



Spindle Mount (parts 14 & 16)

OR

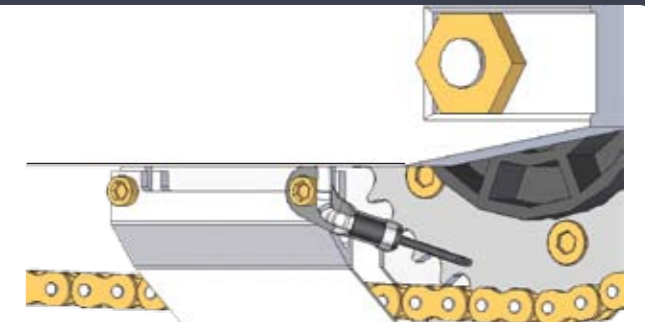

Sprocket guard (parts 15 & 16)

3. Reservoir Metering Valve (RMV)

Mount RMV using cable ties or drill a hole and secure using fasteners.

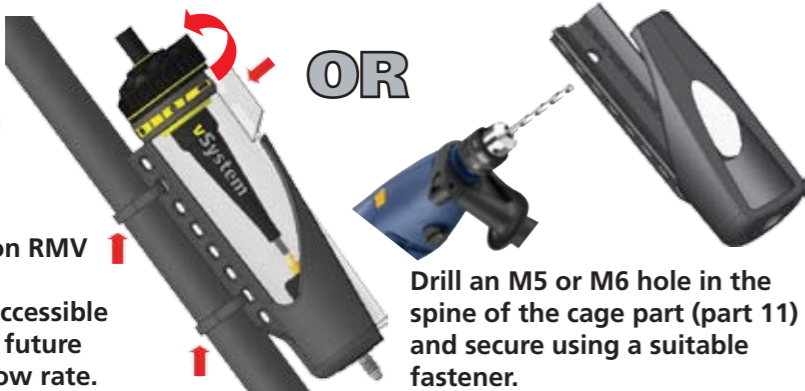

Both Filler hole on RMV & adjuster knob should be kept accessible for re-filling and future adjustment of flow rate.

Drill an M5 or M6 hole in the spine of the cage part (part 11) and secure using a suitable fastener.

! Avoid hot exhaust and engine components

4. Connections

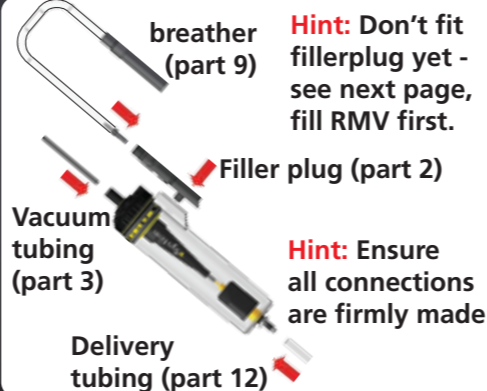

Hint: Don't fit fillerplug yet - see next page, fill RMV first.

Hint: Ensure all connections are firmly made

! Avoid routing against moving parts.

5. Tube Routing

Self adhesive clips (part 22) allow you to neatly route the delivery tubing (part 12) along flat surfaces e.g. the swinging arm. Clean and degrease the surface using the IPA wipe (part 21) provided before attaching. Press clip firmly down for approx 30 seconds to ensure a good bond.

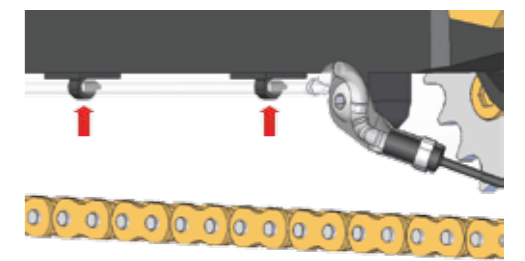

Cable Ties (part 12) can be used to secure vacuum tubing to existing wiring or to the frame or sub-frame to route neatly to the RMV. Take care not to pinch the tubing by over tightening.

continued over

6. RMV Filling

Bottle & Spout (parts 17 & 18)

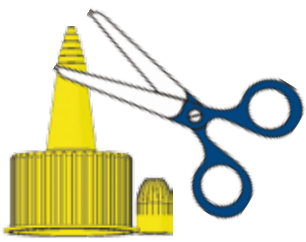

Hint: Always remove filler plug and breather before filling

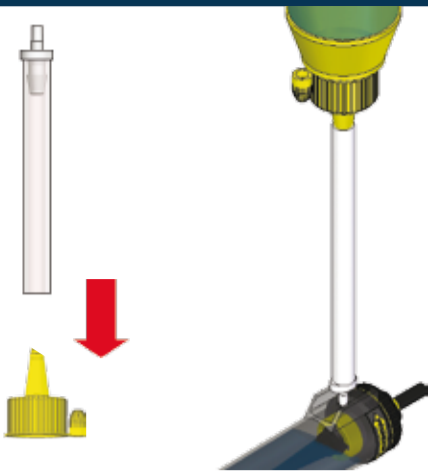

7. Prime System

⚠️ Never attempt to use compressed air

Press Filler plug (part 2) into the RMV and turn the adjuster at the top of the RMV fully clockwise to "Prime" position.

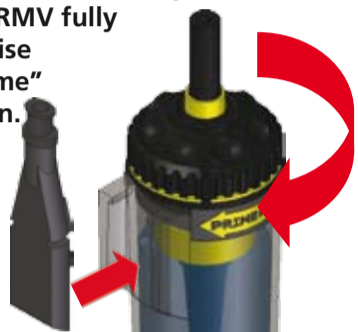

Hint: Hold bottle upright



Connect the spout to the Filler Plug, and squeeze the bottle of oil to pressurise the system. This will force oil down the delivery tubing. Squeeze until there are no bubbles.

8. Set Flow Rate

Start your bike, allow the engine to warm up

Adjust the flow until approx. 1 drop per minute is achieved

Check flow after a short journey, adjust if necessary.

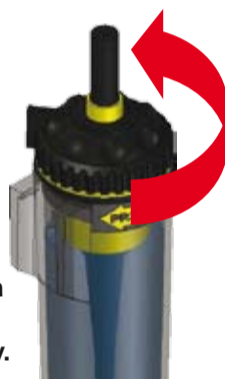

Hint: 1 drop per minute provides the optimal flow rate



How It Works

Only 3ccs of air moves back and forwards so no engine interference

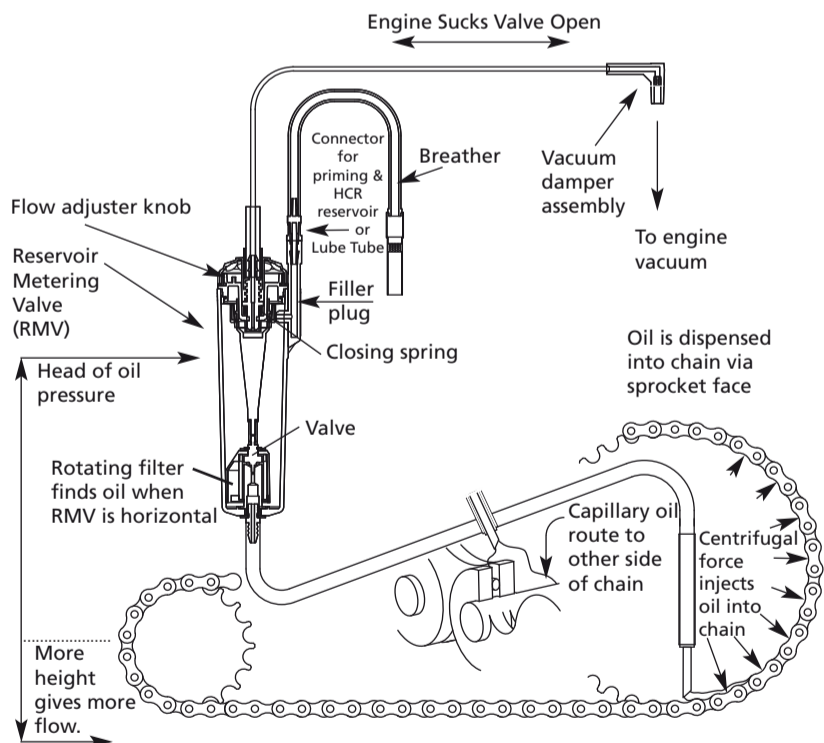

How does the Scottoil work? The Scottoil vSystem is vacuum operated. When the motorcycle engine is running vacuum is generated, this lifts a diaphragm which in turn opens the valve. Whilst open the valve allows oil to drip feed under gravity down the delivery tube to the chain via the rear sprocket. There is metering built into the valve to provide adjustment to control the rate at which oil is dispensed. It is not a pump.

How does this affect the engine? It doesn't. The Scottoil's output is not affected by engine speed, throttle opening and so on. The vacuum chamber is a sealed unit and does not affect the running of the bike. Upon starting the engine the valve will open, this requires 3cc of air to be moved in order to lift the diaphragm, which stays up until the engine is switched off. It is not unusual to see the diaphragm pulsating with very low revs, particularly on singles and twins, don't confuse this for a pumping action, it is not a pump.

Limited Warranty

The Scottoil vSystem is warranted to the original purchaser of the product that it will be free from defects in workmanship and materials under normal use for a period of two years from the date that the product was first purchased. This Limited Warranty covers the repair or replacement of the product only. In order to make a claim you must first have registered your warranty at www.scottoiler.com, then contact Scottoil directly with your claim. This does not affect your legal rights which may vary from state to state.

Parts List

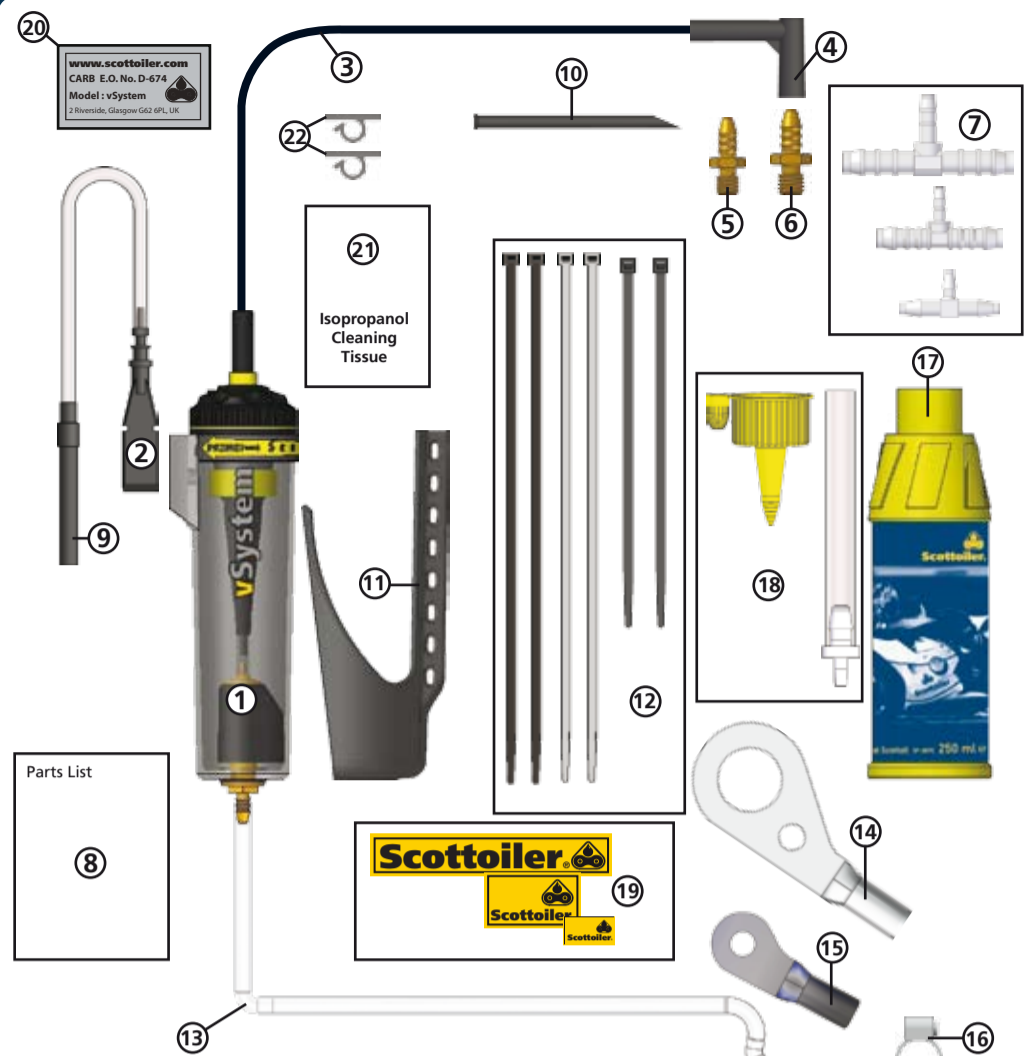

- | | |
|-----------------------------------|------------------------------------|
| 1) RMV (Reservoir Metering Valve) | 12) Cable ties (6 assorted) |
| 2) Filler Plug | 13) Dispenser Assembly |
| 3) Vacuum Tubing (Black) | 14) Dispenser Mounting Plate |
| 4) Vacuum Damper Elbow | 15) Dispenser Mounting Plate Small |
| 5) M5 Spigot | 16) Dispenser Plate Clip |
| 6) M6 Spigot | 17) 250ml Scottoil |
| 7) Tee Pieces (4mm, 6mm, 8mm) | 18) Filling / Priming Spout |
| 8) Instructions | 19) Scottoil Stickers (3 assorted) |
| 9) Breather Assembly | 20) CARB EO Sticker |
| 10) Spare Nib (x2) | 21) Isopropanol Cleaning Tissue |
| 11) RMV Cage | 22) Self Adhesive Clips (x2) |

Frequently Asked Questions (FAQ)

- 1. Which products are suitable for my bike?** Visit our website www.scottoiler.com and select your bike 'Manufacturer' and 'Model'. Select the kit you want and download the installation guide PDF.
- 2. What oil should I use to refill my Scottoil?** In ambient temperatures between 0 and 30 degrees Celcius (32 and 86 degrees Fahrenheit) we recommend Scottoil Traditional - Blue and in ambient temperature between 20 and 40 degrees Celcius (68 and 104 degrees Fahrenheit) we recommend Scottoil High Temperature - Red. Scottoil features a very low tack additive thus not attracting dirt. Scottoil cannot guarantee the compatibility of our systems using any other manufacturers oils as the materials used are tested for compatibility with Scottoil only.
- 3. When should I refill my RMV (Reservoir Metering Valve)?** If you refill the oiler before it runs dry you won't have to prime the dispenser tube. The Reservoir Metering Valve takes around ten seconds to top up with 50ml of oil which should last up to 1,500 miles.
- 4. Can I increase the capacity?** Yes, the Magnum High Capacity Reservoir increases capacity by up to eight times. The HCR is fitted behind the number plate and the combined increased capacity will give up to 10,000 additional miles between refills. Alternatively, the Lube Tube flexible high capacity reservoir increases combined capacity by up to four times. The Lube Tube can be fitted into any dead space on the bike and will mean up to 6,000 additional miles between refills.
- 5. Will the Scottoil only oil one side of my chain?** No. The oil is fed to the chain via the sprocket face where it splits over the inner side plates. Some of the oil is diverted onto the o-rings and the remainder feeds under the roller onto the bushing. Capillary action will then draw the oil across the chain. For best results load the chain with oil from the bottle or a rag after cleaning and then apply approx 1 drop per minute to maintain this film of oil.
- 6. Will I get oil on my tyre?** No, A flow rate of approximately one drop per minute applied via the sprocket face will provide an oil-film which will not pollute the running surface of the tyre and will give a dramatic improvement in chain life. In conditions where high levels of dust, sand or heavy rain are present more oil flow will be necessary to extend chain life.
- 7. When do I need to adjust flow?** Temperature change will alter the flow rate of the oiler. The oil will flow more quickly in warm temperatures as it will get thinner. The oil will flow more slowly in cold temperatures as it will get thicker. It is important to monitor the flow rate with temperature change and adjust flow accordingly.
- 8. I want to move my Scottoil onto my new bike, are the spare parts available separately?** Yes, the full range of spare parts, fittings and accessories are available online at www.scottoiler.com or by telephoning Scottoil on 1-866-995-9340.
- 9. Does this system satisfy the requirements of the Californian Air Resource Board?** Yes. Scottoil have submitted the vSystem kit to the Californian Air Resource Board and have received an Exemption Order (E.O.). The E.O. number is printed on the enclosed sticker (Part A). This sticker should be fixed to the bike near the reservoir (RMV) or actually onto the reservoir (RMV) itself to comply with the CARB requirements for this product.